



Search Electronics, Inc.
 113 N. First Ave., Upland, CA, USA
 Phone: 1-909-949-4215 Fax: 1-909-985-8229
www.searchelec.com

UB6120 (6V12Ah)

NOTE



PHYSICAL SPECIFICATIONS

Nominal Voltage Nominal Capacity (20HR)		6V 12 Ah
Dimensions	Length	151 +/-1mm(5.94 inches)
	Width	50 +/-1mm(1.97 inches)
	Height	94 +/-2mm(3.70 inches)
	Total Height	100 +/-2mm(3.94 inches)
Weight		Approx. 2.10 kg (4.63lbs)
Standard Terminal		F1 – Faston Tab No.187

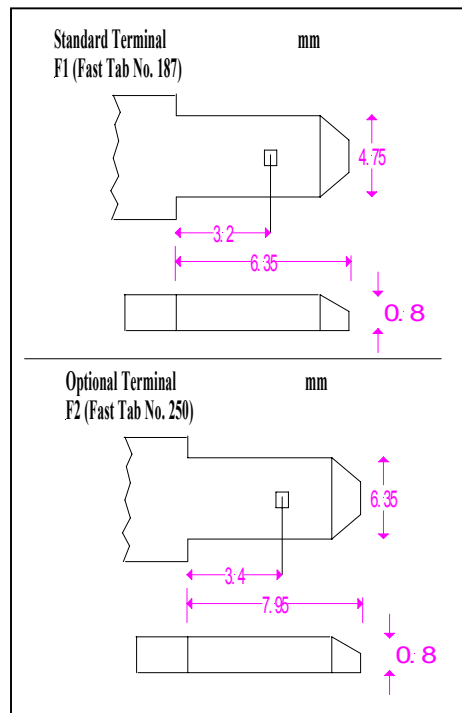
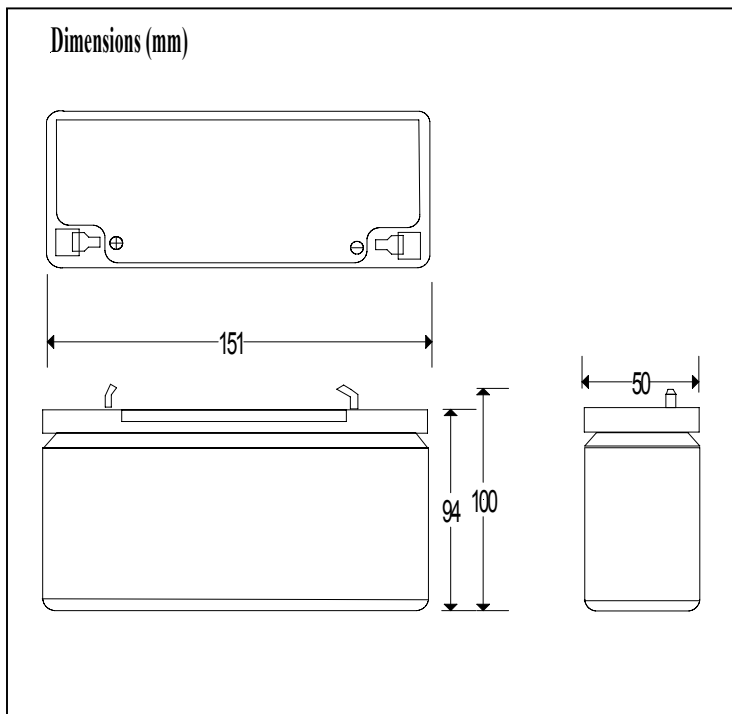



ELECTRICAL SPECIFICATIONS

Capacity	20 hour rate (0.35A)	12 Ah	Max. Discharge Current (5 sec.)		100A
	10 hour rate (0.63A)	10.8 Ah	Constant Voltage Charge	Cycle	Initial Charging Current less than 3.6A Voltage 7.20V ~ 7.50V at 20°C(68°F) Temp. Coefficient-15mV/°C
5 hour rate (1.12A)	9.6 Ah				
1 hour rate (4.2A)	7.2 Ah				
Capacity affected by Temperature	40°C(104°F)	105%	Standby	Initial Charging Current less than 3.6A Voltage 6.75V ~ 6.90V at 20°C (68°F) Temp. Coefficient-10mV/°C	
	20°C(68°F)	100%			
	0°C(32°F)	85%			
Internal Resistance Fully charged battery (20°C, 68°F) 35mΩ					

